

349

Frozen Carbonated Beverage (FCB) Freezer

Four Flavor

Features

Dispense a light, fluffy, high overrun slush product in a pressurized system. Optional non-pressurized system produces a wetter, lower overrun slush.

Freezing Cylinder

Four, 7 quart (6.6 liter).

Dispensing Door

Clear plastic dispensing doors with self closing draw handles are standard. Round dispensing nozzle conveniently fits the hole in domed lids.

Electronic Control

Slushtech™ is standard with our exclusive microprocessor based universal control which regulates refrigeration by measuring product viscosity. Self diagnostic features aid in serviceability.

Syrup

Designed to use FCB syrup in bag-in-box packaging. Optional syrup tank fittings are available for using syrup in tanks.

Carbonation System

Self-contained carbonation system supplies carbonated water at the set pressure. Sure Set Flow Control automatically maintains brix settings by compensating for fluctuations in water, CO₂, and syrup pressures. Soda water flow is preset at the factory.

Indicator Lights/Audible Alarm

Lights flash and audible alarm sounds to indicate loss of CO₂, water or syrup. If syrup is out on one side, the opposite side will continue to operate. A snooze feature may be activated to silence the alarm for 30 minutes.

Automatic Defrost

Programmable defrost cycles allow the operator to select the time and frequency for defrosting each freezing cylinder independently. The defrost light flashes to warn customers not to draw product from the side that is being defrosted. At the end of the defrost cycle, the freezer automatically returns the product to serving viscosity.

Power Saver

During extended no-use periods, the Power Saver feature may be programmed for either Standby or Rest Mode. Standby Mode maintains product in freezing cylinder between 35 & 40°F (1.6 & 4.4°C) for quickest return to serving product. Rest Mode shuts down the refrigeration system for the most energy savings. Start and end times may be programmed independently for seven cycles.

Air Filter

Removable, cleanable air filters help keep condensers clean for optimal refrigeration system performance.

Preventative maintenance programs are available through your local Taylor distributor.



Doors for Non-pressurized Option



349 Frozen Carbonated Beverage (FCB) Freezer

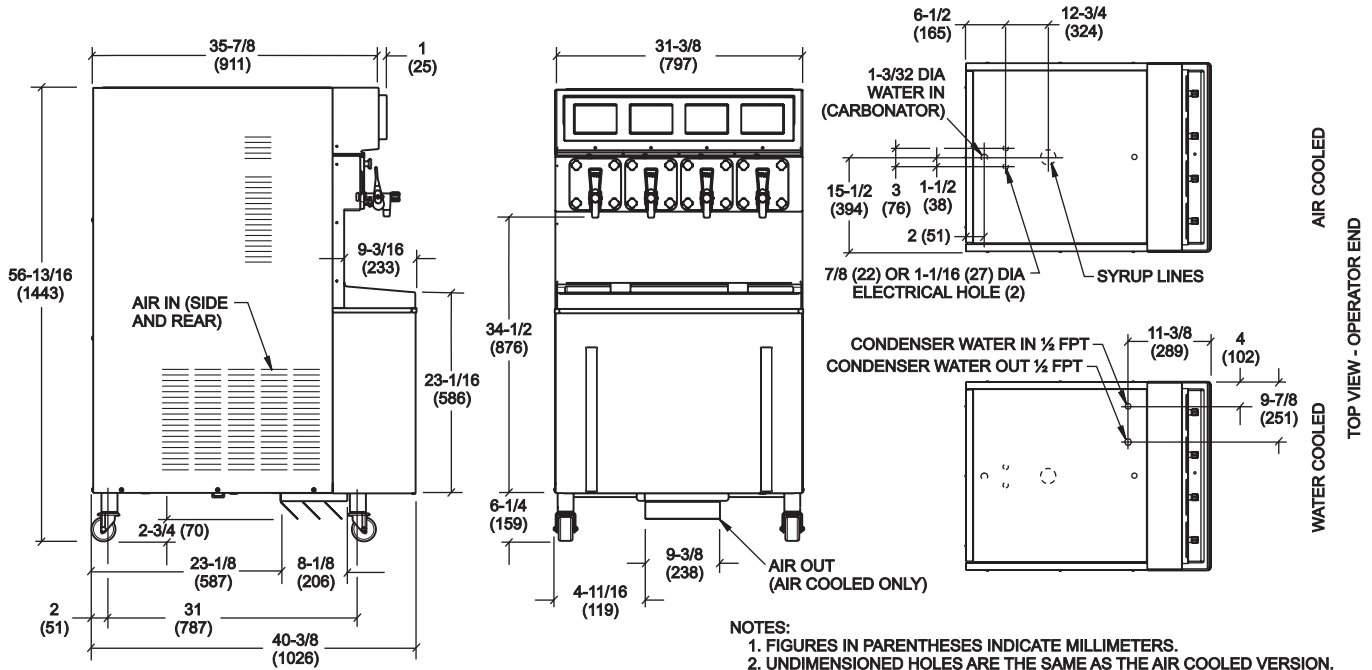

| Weights | lbs. | kgs. |
|-----------------|----------|--------|
| Net | 895 | 405.9 |
| Crated | 955 | 433.2 |
| | cu. ft. | cu. m. |
| Volume | 63.2 | 1.78 |
| Dimensions | in. | mm. |
| Width | 31-3/8 | 797 |
| Depth | 40-3/8 | 1026 |
| Height | 56-13/16 | 1443 |
| Floor Clearance | 6-1/4 | 159 |

*Mounted on standard casters

| Electrical | Maximum Fuse Size | Minimum Circuit Ampacity | Poles (P) Wires (W) |
|--------------------|-------------------|--------------------------|---------------------|
| 208-230/60/1 Air | 45 | 38 | 2P 3W |
| 208-230/60/1 Water | 40 | 35 | 2P 3W |
| 208-230/60/3 Air | 30 | 28 | 3P 4W |
| 208-230/60/3 Water | 30 | 26 | 3P 4W |
| 380-415/50/3N~ Air | 20 | 23 | 4P 5W |

This unit may be manufactured in other electrical characteristics. Refer to the local Taylor Distributor for availability.
 (For exact electrical information, always refer to the data label of the unit.)

Bidding Specs

Electrical: Volt _____ Hz _____ ph _____
 Neutral: Yes No **Cooling:** Air Water NA

Options: _____

Continuing research results in steady improvements; therefore, these specifications are subject to change without notice.

Specifications

Electrical

One dedicated electrical connection is standard. (Two dedicated electrical connections is optional.) See the Electrical chart for the proper electrical requirements. Manufactured to be permanently connected. Consult your local Taylor distributor for cord & receptacle specifications as local codes allow.

Beater Motor

Two, 1/2 HP.

Refrigeration System

Two, 14,000 BTU/hr compressor (nominal rating). R404A.
 (Actual BTUs will vary based on application.)

Potable Water Pressure

Minimum 25 PSI for proper operation of carbonation system.

Air Cooled

Minimum Clearance: 6" (152 mm) around all sides. Minimum air clearances must be met to assure adequate air flow for optimum performance.

Water Cooled

Water inlet and drain connections under side of base 1/2" FPT.

Options

- Non-pressurized
- Non-pressurized, Remote Condenser, High Capacity (two, 18,000 BTU/hr Compressors)
- Side Cup Dispensers
- Syrup Tank Fittings
- Water Cooled, Hi Capacity. Two, 17,000 btu/hr compressor (nominal rating)

Syrup pumps for the Bag in the Box syrups are required. Consult your local Taylor distributor for availability.



Taylor Company,
 A Division of Carrier Commercial Refrigeration, Inc.
 Rockton, Illinois 61072
 815-624-8333 **800-255-0626** Fax 815-624-8000
www.taylor-company.com

Printed in U.S.A.

043203-ADV

6/06