



Item No. \_\_\_\_\_

# 441

## Shake Freezer

Single Flavor

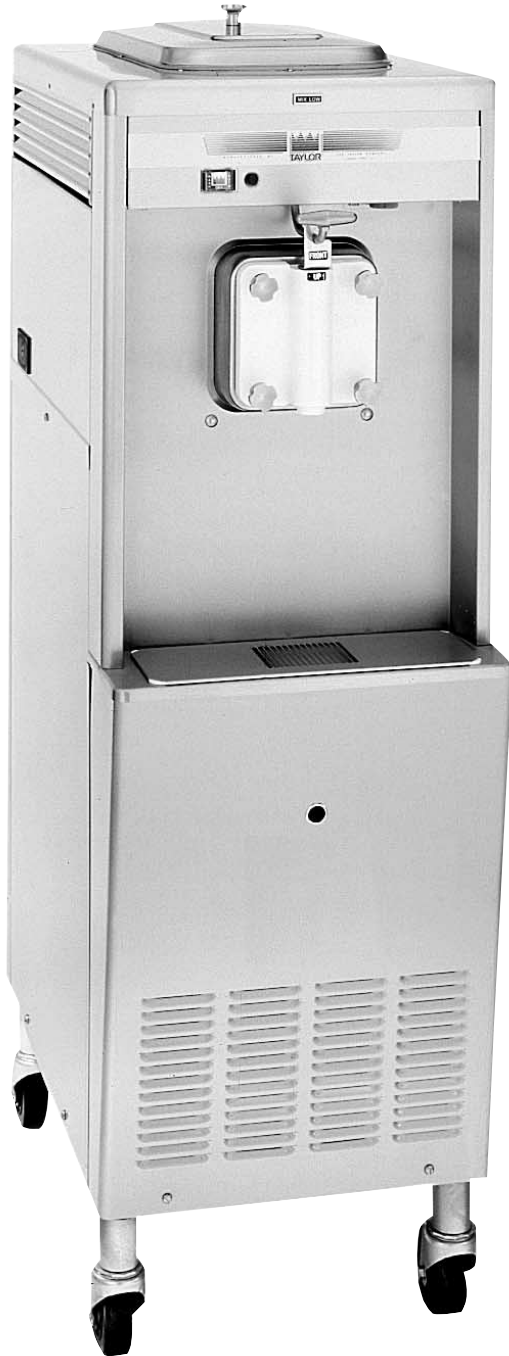

### Features

Serve a wide variety of frozen beverages, like shakes and smoothies, with the assurance of safe temperatures for dairy products. Direct draw a single flavor, or blend in flavorings for more variety.

#### Freezing Cylinder

One, 7 quart (6.6 liter).

#### Refrigerated Mix Hopper

One, 20 quart (18.9 liter). Separate hopper refrigeration (SHR) maintains mix below 41°F (5°C).

#### Indicator Lights

Add Mix light alerts the operator to add mix.

#### Solid State Controls

Thermistor control precisely monitors temperature and maintains consistent quality in product texture through solid state technology.

441



Standard 6



SA2650



Selected 50 Hz. Models

Rockton, Illinois 61072  
**800-255-0626**  
Phone 815-624-8333 Fax 815-624-8000  
**www.taylor-company.com**  
e-mail: info@taylor-company.com

International Office  
Taylor Company S.r.l.  
Roma, Italy  
Tel: **+39-06-420-12002** Fax: +39-06-420-12034  
e-mail: romeoff@taylor-company.com

ISO 9001:2000  
Registered Firm

# 441 Shake Freezer

441

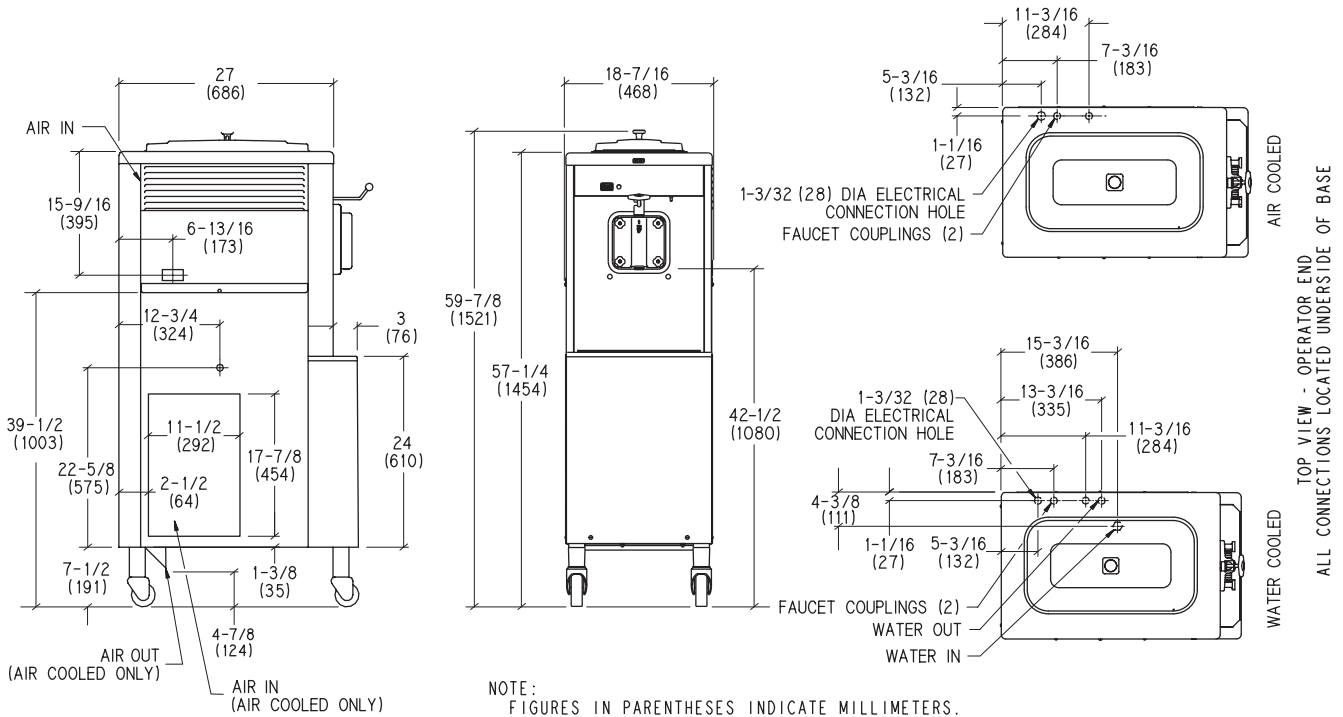

Weights	lbs.	kgs.
Net	415	188.2
Crated	498	225.9
	cu. ft.	cu. m.
Volume	35.4	1.0

Dimensions	in.	mm.
Width	18-7/16	468
Depth	30	762
Height	59-7/8	1521
Counter Clearance	7-1/2	191

\*Mounted on standard casters

Electrical	Maximum Fuse Size	Minimum Circuit Ampacity	Poles (P) Wires (W)
208-230/60/1 Air	30	22	2P 3W
208-230/60/1 Water	25	19	2P 3W
208-230/60/3 Air	20	15	3P 4W
208-230/60/3 Water	15	12	3P 4W
220-240/50/1 Air	20	16	2P 3W
380-415/50/3N~ Air	12	10	4P 5W

This unit may be manufactured in other electrical characteristics. Refer to the local Taylor Distributor for availability. (For exact electrical information, always refer to the data label of the unit.)

## Bidding Specs

Electrical: Volt \_\_\_\_\_ Hz \_\_\_\_\_ ph \_\_\_\_\_

Neutral:  Yes  No Cooling:  Air  Water  NA

Options: \_\_\_\_\_

## Specifications

### Electrical

One dedicated electrical connection is required. See the Electrical chart for the proper electrical requirements. Manufactured to be permanently connected. Consult your local Taylor distributor for cord & receptacle specifications as local codes allow.

### Beater Motor

One, 1.0 HP

### Refrigeration System

One, 11,000 BTU/hr. R404A.

Separate Hopper Refrigeration (SHR), One, 400 BTU/hr. R134a. (BTUs may vary depending on compressor used.)

### Air Cooled

Minimum 3" (76 mm) around all sides. Install the deflector provided to prevent recirculation of warm air. Minimum air clearances must be met to assure adequate air flow for optimum performance.

### Water Cooled

Water inlet and drain connections under side of base 3/8" FPT.

## Options

- Door Spinner
- Faucet
- Foot Pedal
- Panel Spinner
- Refrigerated Syrup Rail, 3 compartment & Panel Spinner

Continuing research results in steady improvements; therefore, these specifications are subject to change without notice.